

FEATURES

- Miniature, ultra-low power valves for use in potentially explosive atmospheres according to ATEX Directive 94/9/EC
- EC type examination certificate (IBEx U01 ATEX 1060 X) is in compliance with European Standards EN 60079-0, EN 60079-11, EN 60079-26, EN 61241-0 and EN 61241-11
- Intrinsically safe design (class Ex ia) approved for use in potentially explosive atmospheres of group IIC and temperature class T6. It can be suitable for oil, gas, paint manufacturing and application industries
- Specially designed for applications where there is a requirement for low power consumption, low weight and low bulk combined with excellent flow/pressure characteristics. They can be used in zone 0, and are also perfectly suitable for other zones. Electrical connection can be made with cable type A or B according to EN 50039

GENERAL

Differential pressure	2 - 8 bar [1 bar = 100 kPa]	
Pneumatic base	ISO 15218 (CNOMO E06.36.120N, size 15) or ISO 15218 (CNOMO E06.05.80N, size 30) with adapter	
Response time (ms)	NC	NO
	6 V	780
	8 V	650
	12 V	320
	24 V	130

fluids (*)	temperature range (TS)	seal materials (*)
air or inert gas dry, filtered (5 µm, 6V, 8V and 12V versions, or 25 µm, 24V version), without condensate, dew point: -20°C	- 20°C to + 50°C	NBR (nitrile)

MATERIALS IN CONTACT WITH FLUID



(*) Ensure that the compatibility of the fluids in contact with the materials is verified

Body	PPS
Internal parts	Piezo ceramics
Seals	NBR
Subbase	Brass, PA or zinc diecast

ELECTRICAL CHARACTERISTICS

Connector	Spade plug (cable Ø 6-7 mm)
Connector specification	DIN 43650, 9,4 mm, industry standard B or 2 lead outlet, length 1 m
Electrical safety	IEC 335
Electrical enclosure protection	Moulded IP65 (EN 60529)
Standard voltages	DC (=) : 6V, 8V, 12V, 24V
Duty cycle	100%

SAFETY CODE

 II 1G Ex ia IIC T6
 II 1D Ex iaD 20 T 85°C

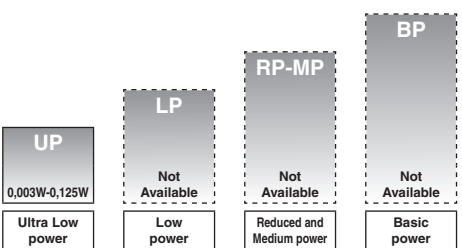
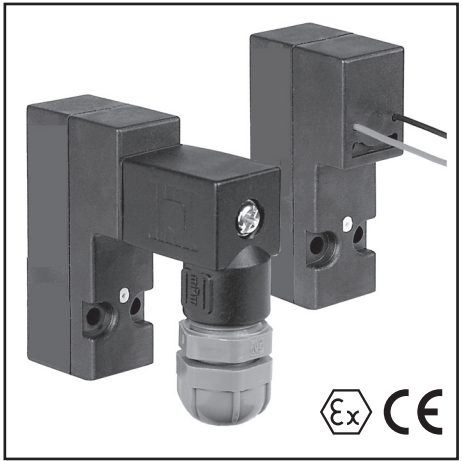

POWER LEVELS - cold electrical holding values (watt)

voltage (U _n) (max. ripple 10%)	power ratings hot/cold =	holding current I _N	typical functional ratings					operator ambient temperature range (TS)	type ⁽³⁾
			U ₂ (ON) turn on	U ₂ (OFF) turn off	I _(peak) peak	I _(hold) hold	R _s + R _c barrier + cable		
(V)	(W)	(mA)	(V)	(V)	(mA)	(mA)	max. (Ω)	(°C) ⁽¹⁾	
Ultra low power (UP)									
6	0,003	0,5	6..9	3	6	0,5	1200	-20 to +50	01-02
8	0,022	2,9	7,2..12	3,2	10	2,8	300		
12 (12 mW version)	0,012	1	10,8..16	3,3	6,8	1	1200		
12 (32 mW version)	0,032	2,7	10,8..16	3,3	8,1	2,7	470		
24 (46 mW version)	0,046	1,9	21,6..28	5	10	1,9	1200		
24 (125 mW version)	0,125	5,2	21,6..28	5	14	5,2	470		

power level	safety parameters				
	U _i = (DC)	I _i	P _i	L _i	C _i
(W)	(V)	(V)	(W)	(H)	(mF)
Ultra low power (UP)					
All versions	30	200	0,9	0	0

Example of use with a Zener barrier installed in a non-hazardous zone:
 safe area (RS interface) cable explosive area

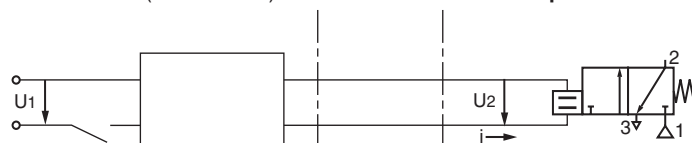

TEMPERATURE CLASSIFICATION TABLES DC (=)

power level (watt)	maximum ambient °C ⁽¹⁾		
	surface temperature		
	T6 85°C	T5 100°C	T4 135°C
Insulation class F (155°C) 100% E.D. ⁽²⁾			
All	50	-	-

- ⁽¹⁾ The minimum allowable ambient temperature is -20°C
- ⁽²⁾ The piezo-valve is designed for continuous duty within the maximum ambient temperature limits. This intrinsically safe piezo-valve must be connected to a specific, approved power supply (safety barrier or interface) located in a safe area. See list of safety barriers/interfaces on page 2.
- ⁽³⁾ Refer to the dimensional drawings on the following page.
- ⁽⁴⁾ Not to be used as a safety valve.

ELECTRICAL CONNECTION (piezo-valves have polarization)



SPECIFICATIONS

pipe size	flow coefficient Kv		operating pressure differential (bar)		voltage	power ratings (W)	(M)	catalogue number	
			min.	max. (PS)				spade plug connection with connector	with 2-lead outlet
	(m³/h)	(l/min)		=	(V)	=	=	=	
NC - Normally closed (PISCIS prefix)									
pad mounting	0,015	0,026	2	8	6	0,003	X	63000061	63000062
							▼	63000059	63000060
	0,002	0,033	2	8	8	0,022	X	63000091	63000092
							▼	63000093	63000094
							X	63000051	63000055
							▼	63000053	63000057
					12	0,012	X	63000095	63000096
							▼	63000097	63000098
						0,032	X	63000043	63000047
							▼	63000045	63000049
24	0,046	X	63000099	63000100					
		▼	63000101	63000102					
NO - Normally open									
pad mounting	0,002	0,033	2	8	12	0,012	X	63000052	63000056
							▼	63000054	63000058
					24	0,046	X	63000044	63000048
							▼	63000046	63000050

(M) : Type of manual operator: X : without ▼ : impulse

SUBBASES

pipe size	designation	catalogue number
Aluminium subbases		
M5 ⁽¹⁾ , tapped	single subbase (M5 lateral connection)	88263002 ⁽²⁾
-	intermediate subbase, adapter for mounting of Piezotronic valve, NC, series 630, on CNOMO interface E06.05.80 (30x30)	30300001
Brass subbase		
M5 ⁽¹⁾ , tapped	single subbase (M5 lateral connection)	88263001 ⁽²⁾
Zamak subbases		
G 1/8 ⁽¹⁾ , tapped	laterally-connected single subbase	35300047 ^{(1) (2)}
G 1/8 ⁽¹⁾ , tapped	joinable subbase	35300047 ⁽²⁾

⁽¹⁾ Subbases with a CNOMO E06.05.80 interface (30x30) require the adapter 88263001 for Piezotronic valves mounting.

⁽²⁾ Assembly safety code [solenoid valve + subbase(s)]: II 2GD IP65 EEx ia IIC T6 .

INSTALLATION

- The solenoid valves can be mounted in any position without affecting operation
- Solenoid valve supplied with mounting screws
- Pipe connections G 1/8 have standard thread according to ISO 228/1
- Electrical connection between solenoid valve and barrier/interface with cable type A or B according to EN 50039
- Installation/maintenance instructions are included with each valve

RECOMMENDED INTERFACES

Located in safe areas, these barriers and interfaces allow to feed the intrinsically safe, piezotronic valves series 630 located in explosive areas.

This equipment must be ordered from its respective manufacturers, specifying that they are intended to feed intrinsically safe, Piezotronic valves: II 1G Ex ia IIC T6, II 1D Ex iaD 20 T 85°C - IBExU01 ATEX 1060 X.

manufacturer	module type	system	Piezotronic 6 V / 22 mW	Piezotronic 8 V / 22 mW	Piezotronic 12V / 12 mW	Piezotronic 12V / 32 mW	Piezotronic 24V / 46 mW	Piezotronic 24V/125 mW
CEAG	FB 6208						x	x
Pepperl + Fuchs	FDO-VC-Ex4.PA	Profibus	x					x
Stahl	9475/12-04-11	Profibus DP or Modbus RTU				x		
	9475/12-04-21	Profibus DP or Modbus RTU						x
	9475/12-04-31	Profibus DP or Modbus RTU						x
	9475/12-08-41	Profibus DP or Modbus RTU	x	x				
	9475/12-08-51	Profibus DP or Modbus RTU				x		
	9475/12-08-61	Profibus DP or Modbus RTU					x	x
Turck	AS 80-Ex	Sensoplex II			x			
	DM 80-Ex	Sensoplex II		x				
AP3	NAEV30-DO4H-C024-0						x	x
	NAEV30-DO4L-C024-0						x	
ABB	DX910S	Point to point or Profibus DP	x					

For additional compatible barriers and interfaces, please contact us.

In accordance with the zone classification and the national legislation of each country, apply the certification procedures for the connection of IS-rated products with associated equipment.

All information subject to change without notice. All responsibility for the use of products from other suppliers and the possible modifications of their characteristics is disclaimed.

All leaflets are available on: www.asco-process-scope.com

DIMENSIONS (mm), WEIGHT (kg)



TYPE 01:
Piezo-valves (NC = PISCIS prefix)
Ultra low power
EN 60079-11, EN 60079-26, EN 61241-11
II 1G Ex ia IIC T6,
II 1D Ex iaD 20 T85°C
IP65
Weight: 0,031 kg

63000061/059/091/083/051/053/095/097/043/045/099/101/052/054/044/046

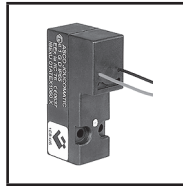

TYPE 02:
Piezo-valves with 2-lead outlet
Ultra low power
EN 60079-11, EN 60079-26, EN 61241-11
II 1G Ex ia IIC T6,
II 1D Ex iaD 20 T85°C
IP65
Weight: 0,023 kg

63000062/060/092/094/055/057/096/098/047/049/100/102/056/058/048/0506/058/048/050

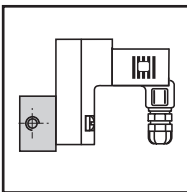
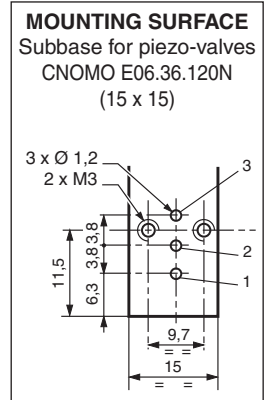
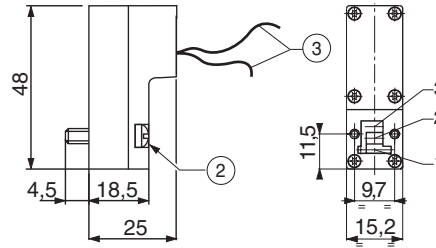
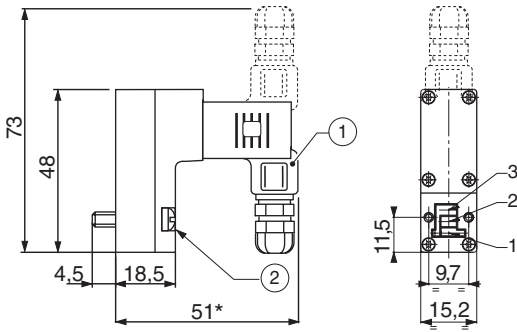

TYPE 03
Single M5 subbases,
aluminium (0,011 kg) or brass (0,032 kg)

88263002 (aluminium) or 30300001 (brass)

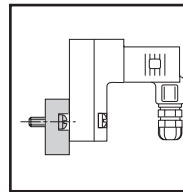

TYPE 04
CNOMO adapter 30x30
(Only for NC version)
Weight: 0,018 kg

88263001

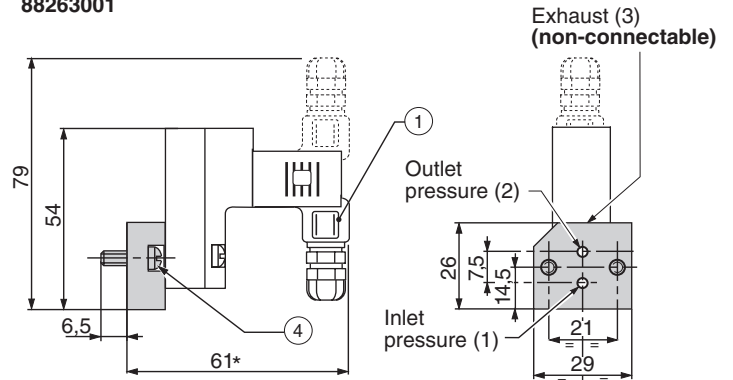
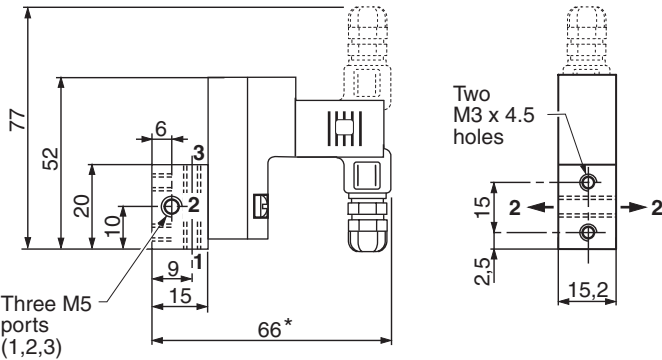

Single subbase connection:
Outlet port (2) can be connected on the left or the right side of the subbase. Close the unused port with a Ø M5 plug (supplied).

- ① Plug connector size 15, rotatable by 90°, cable Ø 6-7 mm
- ② Secured by two screws CM3x20
- ③ 2 leads, length 1 m
- ④ Secured by two screws CM4x10
- (*) +10 mm for connector removal

DIMENSIONS (mm), WEIGHT (kg)

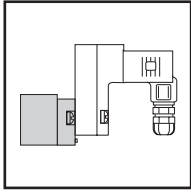

TYPE 05

CNOMO size 30 adapter + Single G 1/8 subbase

Total weight (with NC solenoid valve and connector): 0,118 kg

88263001 + 35300047

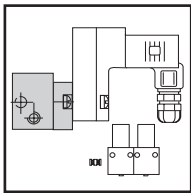
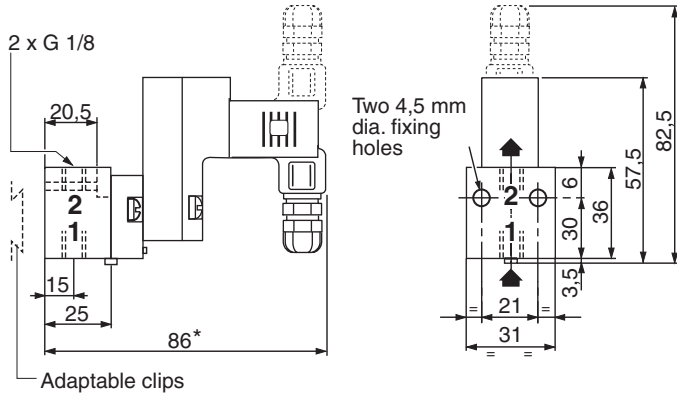

TYPE 6

CNOMO size 30 adapter + joinable G 1/8 subbase

Total weight (with NC solenoid valve and connector): see table

88263001 + 35300048

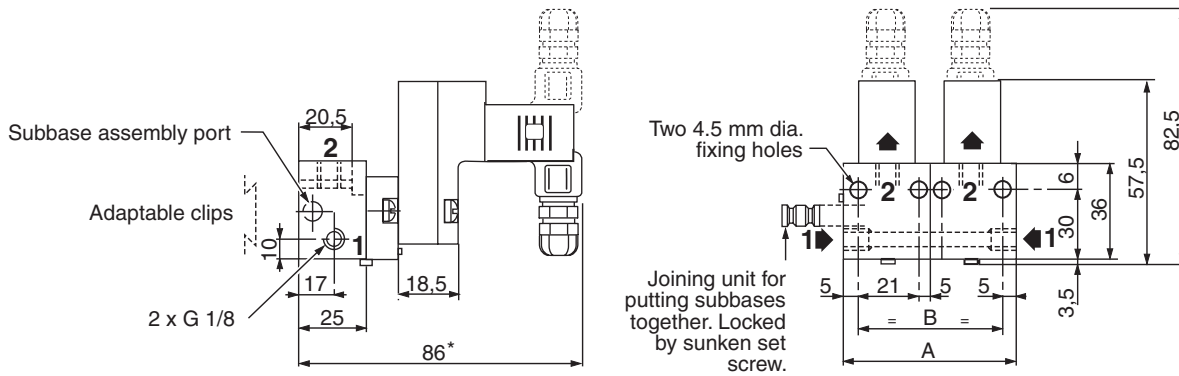

Subbases supplied with seals, screws and joining units for gang mounting

* +10 mm for connector removal

dimension and weight	number of subbases							
	2	3	4	5	6	7	8	
A	62	93	124	155	186	217	248	
B	52	83	114	145	176	207	238	
weight (kg)	0,363	0,608	0,853	1,098	1,343	1,588	1,833	